



PROMOCIJA

Vaš partner za kvalitetna ročna orodja.
Odkrijte raznoliko ponudbo vrhunskega ročnega orodja po akcijskih cenah.

Slike proizvodov so simbolične. Vse dimenzije so v mm, masa v g.



Posebna ponudba velja od 1. 3. 2025 - 31. 12. 2025.
Vse navedene cene so v EUR in vsebujejo DDV.
Pri cenah in tehničnih podatkih si pridržujemo
pravico popravka morebitnih tiskarskih napak.

**Več kot 140
izdelkov
znižano do
40%**

**MADE
FOR
WORK.**

UNIOR

Podjetje Unior d.d. je proizvajalec ročnega orodja iz Slovenije že od leta 1919, z več kot 2000 zaposlenimi in mednarodno mrežo povezanih podjetij in distributerjev, ki uspešno zastopajo Unior v številnih državah po svetu. Podjetje je razdeljeno na programe Odkovki, Strojegradnja, in Ročno Orodje.



Prednosti našega ročnega orodja so:



Visokokakovostna ročna orodja, izdelana v Evropi (ISO 9001 certificirana), nagrajena z Evropsko blagovno znamko kakovosti z več kot 86 % izdelkov izdelanih v EU: <https://uniortools.com/eng/about-us/eqtm>.



Dobri in stabilni nabavni viri (Unior je solastnik tovarne za predelavo jekla v Sloveniji).



Dolgoletne izkušnje skozi vse proizvodne procese (kovanje, strojna obdelava, toplotna obdelava, površinska zaščita in drugo).



Lasten oddelek za razvoj in kakovost s prostori za testiranje.



Fleksibilnost proizvodnje (celoten krog proizvodne poteka v podjetju).



Doživljenjska garancija za orodje.



Širok nabor različnih orodij in opreme za delavnice, kot so standardna orodja, motoristična orodja, avtomobilska orodja, kolesarska orodja, izolirana orodja (VDE certificirano do 1000 V) in drugo.



Hitra dostava.



Nudimo marketinško, tehnično, prodajno in logistično podporo.



Unior je globalno podjetje, zato se zavedamo, da je strateški pristop k trajnostnemu razvoju nujno potreben, tako za današnji čas kot za prihodnost.

NAMENJENA ZAHTEVNEMU VZDRŽEVANJU V AVTOSERVISNIH DELAVNICAH, V AGRO SERVISIH IN VZDRŽEVANJU V INDUSTRIJI.

Vse orodje je v SOS vložkih

SOS vložki združljivi s predali

1011AEV6 | 621756

Garnitura orodja z vozičkom 940EV6

964/28SOS, 964/29ASOS, 964/32ASOS, 964/30SOS, 964/31SOS, 964/33SOS, 964/34SOS, 940EV6

325 pcs

4.775,64

2.864,90

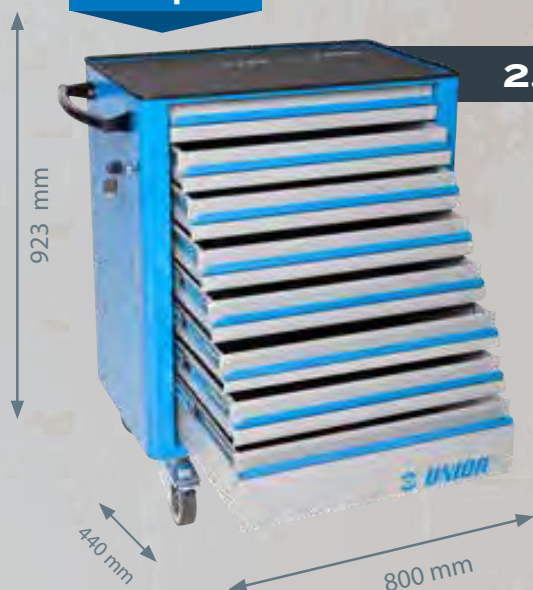

3/3



MADE FOR WORK.

SKENIRAJTE



Slike proizvodov so simbolične. Vse dimenzije so v mm, masa v g.

GARNITURE ORODJA

1011FPLUS3 | 625594

296 kosov

4.755,27

2.849,90

3/3

Garnitura orodja z vozičkom 940PLUS3

964/31SOS, 964/32ASOS, 964/33SOS, 964/28SOS,
964/34SOS, 964/30SOS



SKENIRAJTE

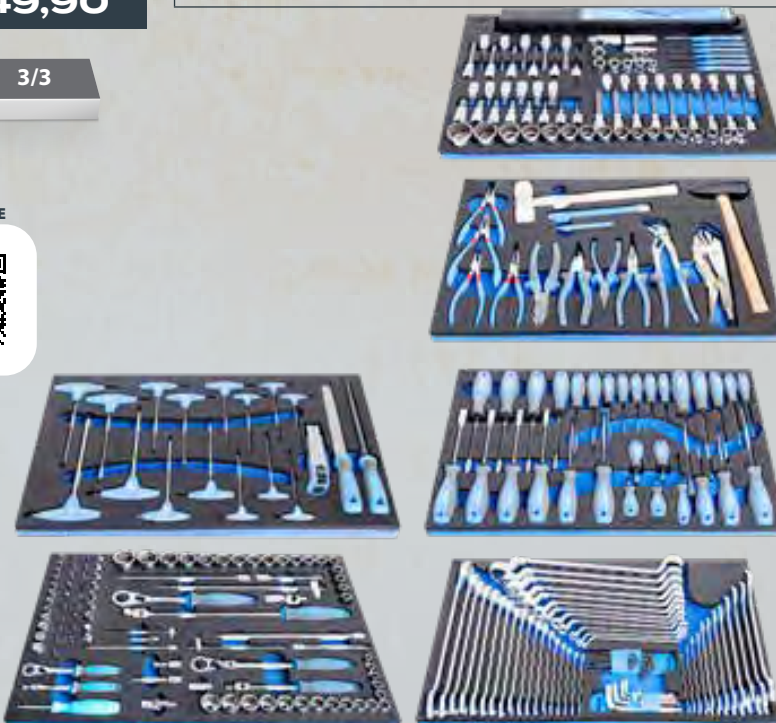

- 100% izvlečni predali z mehkim zapiranjem

1011KEM1 | 629979

Garnitura orodja z vozičkom 940EM1

964/59SOS, 964/60SOS, 964/61SOS

115 kosov

- 100% izvlečni predali z mehkim zapiranjem



1.179,90

1.968,59



MADE FOR WORK.

1012A | 623942

Garnitura orodja za servis težke mehanizacije in vozil

964/28SOS, 964/33SOS, 964/50SOS, 964/51SOS, 964/52SOS, 964/53SOS

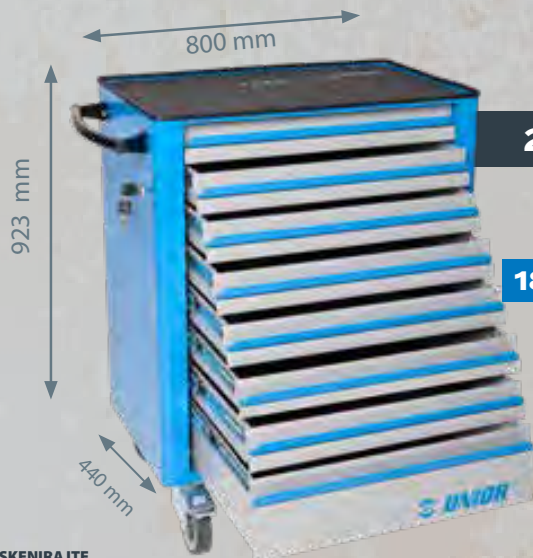

2.289,90

3.820,36

184 kosov

SKENIRAJTE



939/3EV | 620556

Predalnik Eurovision 3-delni

- material: Premium Plus pločevina
- centralno zaklepanje predalov s ključavnico in pregibnim ključem
- 3 predali (2 x L 560 x W 275 x H 70mm, 1 x L 560 x W 315 x H 150mm)

SKENIRAJTE



552,99

329,90

Slike proizvodov so simbolične. Vse dimenzije so v mm, masa v g.

MADE FOR WORK.

GARNITURE ORODJA

192 kosov

1011BEV4 | 621757

Garnitura orodja z vozičkom 940EV4

2.920,31

1.749,90

964/32ASOS, 964/35SOS, 964/36SOS, 964/37SOS, 940EV4

3/3



SKENIRAJTE



1011CEV4 | 624137

Garnitura orodja z vozičkom 940EV4

964/46SOS, 964/47SOS, 964/48SOS, 964/49SOS, 940EV4

3/3

127 pcs

2.371,39

1.419,90



SKENIRAJTE



MADE FOR WORK.



92 kosov

1011GECO | 625595

Garnitura orodja z vozičkom

940ECO

- 6 predalov (4 x L 498 x W 273 x H 70 mm, 2 x L 498 x W 311 x H 150 mm)
- maksimalna nosilnost posameznega predala: 30kg

964ECO2A, 964ECO6, 964ECO9, 964ECO19, 964ECO5, 940ECO

1/2



1.561,88

936,90



SKENIRAJTE

238 kosov

3.755,16

2.249,90



1011DEV6 | 624138

Garnitura orodja z vozičkom

940EV6

- 8 predalov (7x D 563 x Š 365 x V 70mm, 1x D 563 x Š 383 x V 150mm)
- skupna prostornina predalov: 135 litrov

964/28SOS, 964/29ASOS, 964/30SOS, 964/33SOS, 964/48SOS, 964/49SOS, 940EV6

3/3



SKENIRAJTE

Slike proizvodov so simbolične. Vse dimenzije so v mm, masa v g.



Premium+

QualiCoat

SOFTCLOSE

TC KONFIGURATOR
NALEPK



<https://uniortools.com/slo/labelConfig>

MADE FOR WORK.



940PLUS3 | 629590

Voziček za orodje Europlus

- 7 predalov (5x D 563 x Š 365 x V 70mm, 2x D 563 x Š 365 x V 150mm)

1.523,78

899,90

SKENIRAJTE



940EM1 | 629589

Voziček za orodje Euromotion

- 7 predalov (5x D 563 x Š 365 x V 70mm, 2x D 563 x Š 365 x V 150mm)

SKENIRAJTE



999,18

598,90



940H4 | 629591

Voziček za orodje Hercules

- 7 predalov (5x D 563 x Š 365 x V 70mm, 2x D 563 x Š 365 x V 150mm)



1182 mm

640 mm

955 mm



SKENIRAJTE

1.584,78

949,90



Slike proizvodov so simbolične. Vse dimenzije so v mm, masa v g.

940ECO | 617227

Voziček za orodje Economic

- 6 predalov (4 x L 498 x W 273 x H 70 mm, 2 x L 498 x W 311 x H 150 mm)
- maksimalna nosilnost posameznega predala: 30kg

SKENIRAJTE



696,35

416,90

oljno in kislinsko odporna kolesa premera 100mm, eno z zavoro, ki blokira vrtenje in obračanje kolesa



MADE FOR WORK.

VOZIČKI ZA ORODJE



940EV4BLOCK | 625000

Voziček za orodje Eurovision

z blok sistemom

- 7 predalov (5x D 563 x Š 365 x V 70mm, 2x D 563 x Š 383 x V 150mm)
- maksimalna nosilnost posameznega predala: 45kg

1.190,71

713,90

SKENIRAJTE



940EV6 | 619886

Voziček za orodje Eurovision

- 8 predalov (7x D 563 x Š 365 x V 70mm, 1x D 563 x Š 383 x V 150mm)
- skupna prostornina predalov: 135 litrov

SKENIRAJTE



923 mm

440 mm

1.172,54

699,90

800 mm

Dodatki

940ES9 | 608973

Polica lesena za 940E in 940EV



124,68

74,90

940ES8 | 608972

Pokrov plastičen za 940E in 940EV



35,82

20,90

940ES7 | 608971

Nosilec steklenic za 940E in 940EV



20,02

11,90

940ES3 | 608925

Garnitura 4 pregrad za 940E



13,90

8,50

940ES3A | 622597

Garnitura pregrad za nizek predal 940E in 940EV



29,23

16,90

MADE FOR WORK.

990ND6 | 625622

Predalnik, ozki, s 6 predali

- 6 predalov (4 x D 374 x Š 570 x V 70 mm, 1 x D 374 x Š 605 x V 150 mm, 1 x D 374 x Š 605 x V 230 mm)
- skupna prostornina predalov: 145 litrov
- maksimalna nosilnost posameznega predala: 50kg



990BIN | 625655

Element s košem in papirjem

- Element vsebuje dva izvlečna predala.
- Spodnji predal vsebuje dve ločeni posodi za smeti, skupne prostornine 50 litrov; v prvo posodo se lahko smeti mečejo skozi loputo na čelni strani predala.
- V zgornji predal je možno namestiti papirnat rolo premera 270mm in dolžine 380mm. V zadnjem delu predala prostor za rezervno rolo.



990CA

Omara z rolojem

- dolžina 1000 mm z 20 kljukami, dolžina 1500mm s 30 kljukami
- ključavnica s ključem vsebuje tudi obesek



625668	1000x125x740	1.070,38	639,90
612330	1500x125x740	1.220,38	729,90

Debelina 40 mm.
Lesena plošča je sestavljena iz 10 slojev.



990TW

Deska

625630	1500 x 750 x 40	357,22	213,90
625631	2000 x 750 x 40	499,05	298,90

Slike proizvodov so simbolične. Vse dimenzije so v mm, masa v g.

MADE FOR WORK.



UNIOR
CONFIGURATOR

S pomočjo Unior 3D konfiguratorja bo vaša sanjska delavnica končno postala realnost! Svojo sanjsko delavnico si preprosto postavite v svojem spletnem okolju. Ko končate, preprosto greste skozi korake in preverite še iz vsake perspektive.

<https://uniortools.com/eng/apps/configurator>

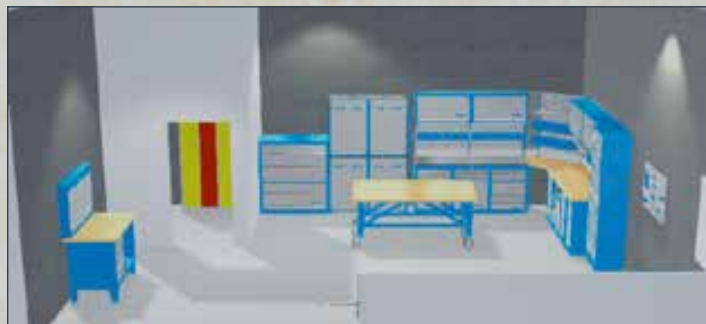

MADE FOR WORK.

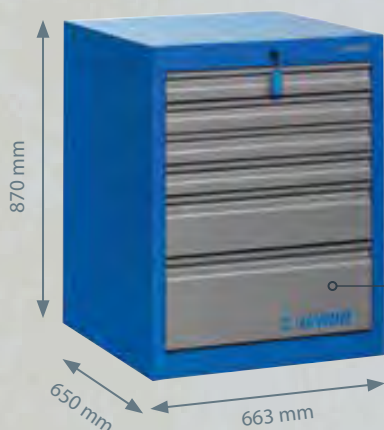

1.312,78

786,90

990WD6 | 625620

Predalnik, široki, s 6 predali

- 6 predalov (4 x D 564 x Š 570 x V 70mm, 1 x D 564 x Š 605 x V 150 mm in 1 x D 564 x Š 605 x V 230 mm)
- skupna prostornina predalov: 220 litrov
- maksimalna nosilnost posameznega predala: 50kg

100% izvlečni predali z visoko kakovostnimi krogličnimi vodili

990WD8 | 625621

Predalnik, široki, z 8 predali

- 8 predalov (7 x D 564 x Š 570 x V 70mm, 1 x D 564 x Š 605 x V 150mm)
- maksimalna nosilnost posameznega predala: 50kg

1.451,09

869,90

skupna prostornina predalov: 208 litrov



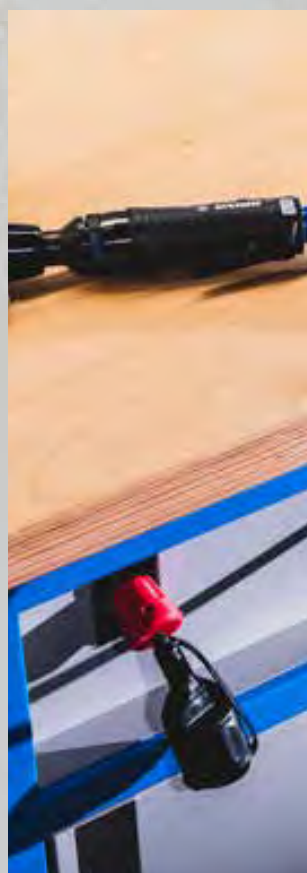

990NDD2 | 625624

Predalnik, ozki, z 2 predaloma

z vrati

- 2 predala (2 x D 374 x Š 570 x V 70 mm)
- z vrati

861,50

515,90

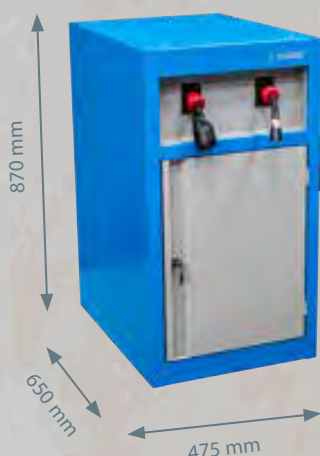

1.484,35

889,90

SKENIRAJTE



990PNE | 625646

Napajalni element za modularni delovni pult

- Napajalni element vsebuje dva bobna z vzmetnim potegom.

990TWS | 625633

Obloga nerjaveča za desko

625633	1500 x 753 x 41	320,79	191,90
625634	2000 x 753 x 41	411,44	245,90



994 | 612208

Mobilni kontrolni voziček

- 2 predala D 563 x Š 365 x V 70mm

972,56

582,90

SKENIRAJTE



Slike proizvodov so simbolične. Vse dimenzije so v mm, masa v g.

963,26

576,90

SKENIRAJTE

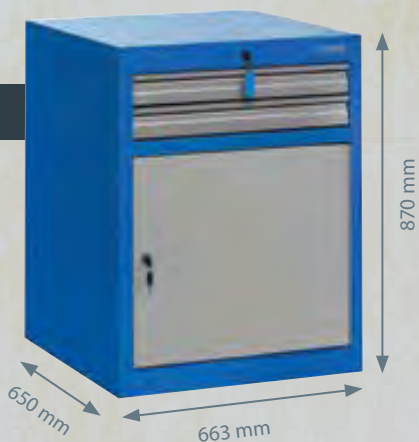

990WDD2 | 625625

Predalnik, široki, z 2 predaloma z vrati

- 2 predala (2 x D 564 x Š 570 x V 70 mm)
- skupna prostornina predalov: 45 litrov
- maksimalna nosilnost posameznega predala: 50kg

990ND8 | 625623

Predalnik, ozki, z 8 predali

- 8 predalov (7 x D 374 x Š 570 x V 70 mm, 1 x D 374 x Š 605 x V 150 mm)
- skupna prostornina predalov: 128 litrov
- maksimalna nosilnost posameznega predala: 50kg

1.281,95

768,90



SKENIRAJTE



MADE FOR WORK.

990MA18 | 627656

Delovni pult - modul A18

5.615,38

3.369,90



SKENIRAJTE



990MA13 | 626731

Delovni pult - modul A13

2.844,47

1.699,90



SKENIRAJTE



2.054,50

1.229,90

990MA14 | 627544

Delovni pult - modul A14

SKENIRAJTE



990MA15 | 627545

Delovni pult - modul A15

985,15

589,90

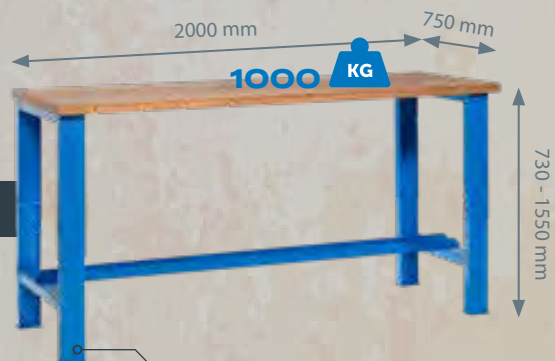

Nastavljiva noga.



990MA12 | 626730

Delovni pult - modul A12

SKENIRAJTE



2.689,90

4.483,46

Slike proizvodov so simbolične. Vse dimenzije so v mm, masa v g.

MADE FOR WORK.

Razporedite svoje orodje glede na svoje potrebe za najbolj učinkovit delovni prostor

Za profesionalne uporabnike

Privlačen izbor

Preprosta izbira

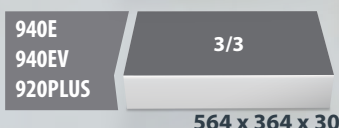

964/31SOS | 621390

Garnitura orodja v SOS vložku

192/2TX (TX 20, TX 25, TX 27, TX 30, TX 40, TX 4, TX 50, TX 55, TX 60),
192/2TXL (TX 20, TX 25, TX 27, TX 30, TX 40, TX 45, TX 50, TX 55, TX 60),
191/1 (E 10, E 11, E 12, E 14, E 16, E 18, E 20, E 22, E 24),
192/2ZX (M 5, M 6, M 8, M 10, M 12, M 14), **192/2ZXL** (M 6, M 8, M 10, M 12, M 14), **192/2HX** (5, 6, 7, 8, 9, 10, 12, 14), **192/2HXL** (5x64, 6x64, 7x64, 8x64, 10x64, 12x64), **190/1 12p** (10, 11, 12, 13, 14, 15, 16, 17, 18, 19, 20, 21, 22, 24, 27, 30, 32), **186.4/2** (16, 19, 21), **641/6** (2, 3, 4, 5, 6, 8), **263** (1/2"/40-200 Nm)

79 kosov



1.012,62

599,90

964/53SOS | 623995

Garnitura nasadnih ključev v SOS vložku

197.1/1 (3/4"x500), **197.3/1** (3/4"), **197.4/1** (3/4"x200, 3/4"x400), **197/1 6p** (22, 24, 27, 30, 32, 36, 38, 41, 46, 50), **197/2AHX** (14, 17, 19, 22), **197.7/1** (3/4" - 1/2"), **190.7/2** (1/2"x3/4"), **2035, 2087**

22 kosov



691,75

414,90

3/3

SKENIRAJTE



MADE FOR WORK.

964/28SOS | 621387

Garnitura ključev v SOS vložku

110/1 (6 x 7, 8 x 9, 10 x 11, 12 x 13, 14 x 15, 16 x 17, 18 x 19, 20 x 22, 21 x 23, 24 x 27, 25 x 28, 30 x 32),
 120/1 (6, 7, 8, 9, 10, 11, 13, 14, 15, 16, 17, 18, 19, 20, 21, 22, 24, 27),
 180/1 (6 x 7, 8 x 9, 10 x 11, 12 x 13, 14 x 15, 16 x 17, 18 x 19, 20 x 22, 21 x 23, 24 x 26, 25 x 28, 27 x 32),
 220/3SPH, 220/7TXPH (TR8 - TR40x9)

3/3

550,88

329,90

60 kosov



obročni del z LIFE profilom

964VDE3BI | 629983

Garnitura izoliranih klešč v vložku

406/1VDEBI (180), **461/1VDEBI** (160), **472/1VDEBI** (160),
 478/1VDEBI (160), **466/1VDEBI** (180), **580/1VDEBI** (170),
 514/1BI (160), **447/1VDEBI** (240), **508/1VDEBI** (170),
 582/3BI (145), **512/1VDEBI** (170)

3/3

406,38

243,90

11 kosov



964VDE8A | 621800

Garnitura izoliranih ploščatih izvijačev VDETBI v SOS vložku

603VDETBI (0.4 x 2.5x75, 0.5 x 3.0x100, 0.6 x 3.5x100, 0.8 x 4.0x100, 1.0 x 4.5x125, 1.0 x 5.5x125, 1.2 x 6.5x150, 1.2 x 8.0x175, 1.6 x 10.0x200),
 630VDE (0.5 x 3.0x140, 0.6 x 3.5x180)

2/3

105,41

62,90

11 kosov



Slike proizvodov so simbolične. Vse dimenzije so v mm, masa v g.

MADE FOR WORK.

GARNITURE ORODJA



14 kosov

6 različnih funkcij

359,17

214,90

3/3

964/32ASOS | 623936

SKENIRAJTE



406/1BI (180), 430/3 (250), 447/1HPP (240),
466/1BI (180), 514/1BI (160), 512/1BI (200),
532PLUS/1DP (180x19 - 60), 534PLUS/1DP (180x19 - 60),
536PLUS/1DP (180x19 - 60), 538PLUS/1DP (180x19 - 60),
642/6 (5), 660/6 (200), 812 (400), 820A (40),
VL964/32ASOS (564x364x30)

Garnitura klešč in kladiv v SOS vložku



96 kosov

752,61

449,90

3/3

964/30SOS | 621389



raglja omogoča delo z nagibom ročaja do max. 90°, s korakom nagiba po 22,5°



75 zob

SKENIRAJTE



Garnitura nasadnih ključev v SOS vložku

188/2 6P (4, 4.5, 5, 5.5, 6, 7, 8, 9, 10, 11, 12, 13), 189/2 (E 4, E 5, E 6, E 7, E 8, E 10, E 11), 187/2HX (3, 4, 5, 6, 7), 187/2TX (TX 8, TX 10, TX 15, TX 20, TX 25, TX 27, TX 30, TX 40), 187/2SL (0.8 x 4, 1.0 x 5.5, 1.2 x 7), 187/2PH (PH 1, PH 2, PH 3), 188.1/1ABI (1/4"), 188.2/2BI (1/4"), 188.3/2 (1/4"), 188.4/2 (1/4"x55, 1/4"x150), 188.6/2 (1/4"), 188.7/2 (1/4" - 3/8"), 188.8 (1/4"), 238/1 6P (6, 7, 8, 9, 10, 11, 12, 13, 14, 15, 16, 17, 18, 19, 20, 21, 22), 238.1/1FBI (3/8"), 238.2/1BI (3/8"), 238.3/1 (3/8"), 238.4/2 (3/8"x45, 3/8"x75), 238.4/1 (3/8"x125, 3/8"x250), 238.6/1 (3/8"), 238.7/1 (3/8" - 1/2"), 190/1 6P (10, 11, 12, 13, 14, 15, 16, 17, 18, 19, 20, 21, 22, 23, 24, 27, 30, 32), 190.1/1ABI (1/2"), 190.2/1BI (1/2"x380), 190.3/1 (1/2"), 190.4/1 (1/2"x250, 1/2"x125), 190.6/2 (1/2"), VL964/30SOS (564x364x30)

MADE FOR WORK.



18 kosov

229,57

137,90



3/3

964/34SOS | 621393

Garnitura izvijačev s T-ročajem, pil in noža v SOS vložku

— 193HXS (2,5, 3, 4, 5, 6, 8, 10), — 193TX (TX 10, TX 15, TX 20, TX 25, TX 27, TX 30, TX 40, TX 45), — 760H1/2S (200), — 764H1/2S (200), — 556B (160x18), — VL964/34SOS (564x364x30)

88 kosov

680,17

407,90



3/3

964/36SOS | 621395

Garnitura nasadnih ključev v SOS vložku

□ 188/2 6P (4, 4.5, 5, 5.5, 6, 7, 8, 9, 10, 11, 12, 13), □ 189/2 (E 4, E 5, E 6, E 7, E 8, E 10, E 11), □ 187/2HX (3, 4, 5, 6, 7), □ 187/2TX (TX 8, TX 10, TX 15, TX 20, TX 25, TX 27, TX 30, TX 40), □ 187/2SL (0.8 x 4, 1.0 x 5.5, 1.2 x 7), □ 187/2PH (PH 1, PH 2, PH 3), ⊕ 188.1/1ABI (1/4"), ⊕ 188.2/2BI (1/4"), ⊕ 188.3/2 (1/4"), ⊕ 188.4/2 (1/4"x55, 1/4"x150), ⊕ 188.6/2 (1/4"), ⊕ 188.7/2 (1/4" - 3/8"), ⊕ 188.8 (1/4"), □ 190/1 6P (10, 11, 12, 13, 14, 15, 16, 17, 18, 19, 20, 21, 22, 23, 24, 27, 30, 32), □ 191/1 (E 10, E 11, E 12, E 14), □ 192/2HX (6, 7, 8, 9, 10, 12), □ 192/2TX (TX 30, TX 40, TX 45, TX 50), □ 192/2ZXL (M 6, M 8, M 10, M 12), ⊕ 190.1/1ABI (1/2"), ⊕ 190.2/1BI (1/2"x380), ⊕ 190.3/1 (1/2"), □ 190.4/1 (1/2"x250, 1/2"x125), □ 190.6/2 (1/2"), VL964/36SOS (564x364x30)

80 kosov

1.103,27

659,90



930 | 601996

Komplet orodja s kaseto 912/5

110/1CB, 180/1CB, ⊕ 212/2 (19), 220/3PB, □ 186.4/2 (21), ⊕ 238.1/1FBI (3/8"), □ 238.4/2 (3/8"x45, 3/8"x75), ⊕ 190.1/1ABI (1/2"), ⊕ 190.2/1BI (1/2"x380), ⊕ 190.3/1 (1/2"), □ 190.4/1 (1/2"x125, 1/2"x250), □ 190.6/2 (1/2"), □ 190/1 6P (10, 11, 12, 13, 14, 15, 16, 17, 18, 19, 20, 21, 22, 23, 24, 27, 30, 32), ⊕ 300/2 (400 (2x)), ⊕ 405/1BI (180), ⊕ 430/3 (175), ⊕ 447/1HPP (240), □ 461/1BI (160), ⊕ 506/1BI (140), ⊕ 514/1BI (160), ⊕ 563R/7PR (280), ⊕ 605TBI (0.8 x 4.0x100, 1.0 x 5.5x125, 1.2 x 6.5x150, 1.2 x 8.0x175), ⊕ 615TBI (PH 2x100, PH 3x150), ⊕ 631 (6 - 12), ⊕ 812 (500), 912/5 (560x210x225)

911/5 | 601909

Kaseta 5 - delna za orodje

SKENIRAJTE



83,20

49,90



MADE FOR WORK.



51 kosov



545,90

971/1BI | 608540

Garnitura orodja v kovčku

1000S, 969S (500x420x200)

111 kosov



1.405,05

842,90

931 | 601995

Komplet orodja s kaseto 912/5

110/1CB, 125/1CB, 180/1CB, 220/2CB, 220/3PB, 186.4/2 (21), 238.1/1FBI (3/8"), 238.4/2 (3/8"x45, 3/8"x75), 190.1/1ABI (1/2"), 190.2/1BI (1/2"x380), 190.3/1 (1/2"), 190.4/1 (1/2"x125, 1/2"x250), 190.6/2 (1/2"), 190/1 6P (10, 11, 12, 13, 14, 15, 16, 17, 18, 19, 20, 21, 22, 23, 24, 27, 30, 32), 300/2 (400 (2x)), 425/4A (1.5 - 6x240), 406/1BI (180), 445/1BI (240), 447/1HPP (240), 461/1BI (160), 514/1BI (160), 563R/7PR (280), 605TBI (0.8 x 4.0x100, 1.0 x 5.5x125, 1.2 x 6.5x150, 1.2 x 8.0x175), 615TBI (PH 1x80, PH 2x100, PH 4x200), 626TBI (PH 2x25), 627TBI (0.8 x 4.0x25), 631 (6 - 12), 640/6 (3, 4), 642/6 (3), 660/6 (150, 200), 670/6 (150), 812 (500), 912/5 (560x210x225)

8 kosov



73,53

43,90

110/1CT | 615465

Garnitura viličastih ključev v torbici

110/1 (6 x 7, 8 x 9, 10 x 11, 12 x 13, 14 x 15, 16 x 17, 18 x 19, 20 x 22)

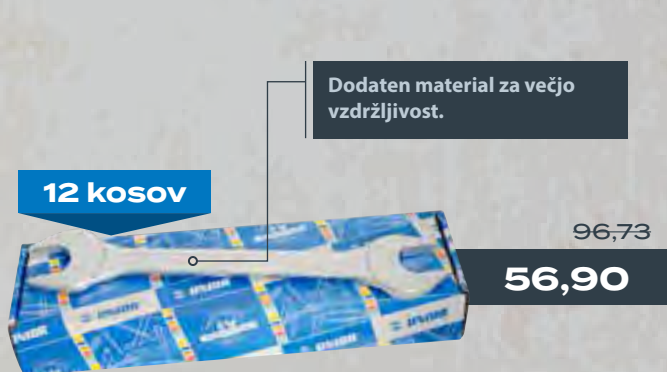

12 kosov

Dodaten material za večjo vzdržljivost.

96,73

56,90

110/1CB | 600106

Garnitura viličastih ključev v kartonu

110/1 (6 x 7, 8 x 9, 10 x 11, 12 x 13, 14 x 15, 16 x 17, 18 x 19, 20 x 22, 21 x 23, 24 x 26, 25 x 28, 27 x 32)



8 kosov

48,19

27,90

110/1CS | 602844

Garnitura viličastih ključev v kartonu

110/1 (6 x 7, 8 x 9, 10 x 11, 12 x 13, 14 x 15, 16 x 17, 18 x 19, 20 x 22)



26 kosov

346,49

207,90

120/1CB | 600384

Garnitura dolgih viličasto obročnih ključev v kartonu

120/1 (6, 7, 8, 9, 10, 11, 12, 13, 14, 15, 16, 17, 18, 19, 20, 21, 22, 23, 24, 25, 26, 27, 28, 29, 30, 32)



12 kosov

184,57

109,90

110/2VDEDP | 612676

Garnitura izoliranih enostranskih viličastih ključev v kartonu

110/2VDEDP (10, 11, 12, 13, 14, 15, 17, 19, 22, 24)



12 kosov

147,57

87,90

180/1CB | 600542

Garnitura obročnih ključev v kartonu

180/1 (6 x 7, 8 x 9, 10 x 11, 12 x 13, 14 x 15, 16 x 17, 18 x 19, 20 x 22, 21 x 23, 24 x 26, 25 x 28, 27 x 32)



10 kosov

198,31

118,90

180/2VDEDP | 612677

Garnitura izoliranih enostranskih obročnih ključev v kartonu

180/2VDEDP (10, 11, 12, 13, 14, 15, 17, 19, 22, 24)



10 kosov

121,34

72,90

193TXCB | 608880

Garnitura ključev s TX profilom in T ročajem v kartonu

193TX (TX6, TX8, TX10, TX15, TX20, TX25, TX27, TX30, TX40, TX45)

GARNITURE ORODJA

11 kosov

144,41

85,90



120/1CB | 629610

Garnitura dolgih viličasto obročnih ključev v kartonu

120/1 (8, 10, 12, 13, 14, 17, 19, 22, 24, 30, 32)

26 kosov

318,36

189,90



125/1CB | 602098

Garnitura kratkih viličasto obročnih ključev v kartonu

125/1 (6, 7, 8, 9, 10, 11, 12, 13, 14, 15, 16, 17, 18, 19, 20, 21, 22, 23, 24, 25, 26, 27, 28, 29, 30, 32)

8 kosov

60,85

35,90



125/1CS | 603711

Garnitura kratkih viličasto obročnih ključev v kartonu

125/1 (8, 9, 10, 12, 13, 14, 17, 19)



233,42

139,90

9 kosov

160/2CB | 623080

Garnitura viličasto obročnih ključev z ragljo v kartonu

160/2 (8, 10, 13, 16, 17, 18, 19, 22, 24)

9 kosov

30,88

18,90



SKENIRAJTE

220/3LPH | 608534

Garnitura dolgih inbus ključev za kotno vijačenje na plastičnem obešalu



220/3SL (1.5, 2, 2.5, 3, 4, 5, 6, 8, 10)

10 kosov

28,80

16,90

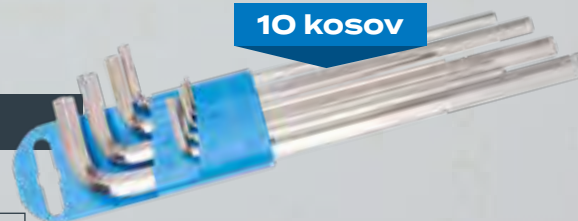

220/3LPH | 617080

Garnitura dolgih inbus ključev na plastičnem obešalu

220/3L (1.5, 2, 2.5, 3, 4, 5, 6, 8, 10, 12)

9 kosov

37,50

22,90



TX8 - TX40

220/7TXNPH | 617077

Garnitura ključev s TX profilom na plastičnem obešalu

SKENIRAJTE



MADE FOR WORK.

183/2CT | 615467

Garnitura ukrivljenih odprtih obročnih ključev



183/2 (8 x 10, 11 x 13, 12 x 14, 16 x 18, 17 x 19, 22 x 24)

80,47

47,90

40 zob
9° kot zasuka

16 kosov



129,09

76,90

188BI | 611996



Garnitura nasadnih ključev 1/4" v kovinski kaseti

188/2 6P (4, 4.5, 5, 5.5, 6, 7, 8, 9, 10, 11, 13), 188.1/1ABI (1/4"), 188.2/2BI (1/4"), 188.3/2 (1/4"), 188.4/2 (1/4" x 55, 1/4" x 150), 981K1/4 (1/4" x 197 x 105 x 38)

SKENIRAJTE



10 kosov

206,81

123,90



231/4PB2 | 612507

Garnitura impact ključev 1/2" v plastični kaseti

231/4L6P (15, 17, 18, 19, 21, 22, 24, 27, 30), 231.4/4 (1/2" x 75), 238.8/4 (10 - 14, 15 - 32)

24 kosov



232,90

138,90

237,72

142,90

44 kosov



188B | 615150



Garnitura nasadnih ključev 1/4" v kovinski kaseti

188/2 6p (4, 4.5, 5, 5.5, 6, 7, 8, 9, 10, 11, 12, 13, 14), 188.1/1ABI (1/4"), 188.3/2 (1/4"), 188.4/2 (1/4" x 55, 1/4" x 150), 188.6/2 (1/4"), 187/2PH (PH 1, PH 2, PH 3), 187/2SL (0.8 x 4, 1.0 x 5.5, 1.2 x 7), 187/2HX (3, 4, 5, 6, 7), 187/2TX (TX 8, TX 10, TX 15, TX 20, TX 25, TX 27, TX 30, TX 40), 189/2 (E 4, E 5, E 6, E 7, E 8, E 10, E 11), 981K3/8 (3/8" x 321 x 198 x 54)

239A | 612509

Garnitura nasadnih ključev 3/8" v kovinski kaseti

238/1 6P (6, 7, 8, 9, 10, 11, 12, 13, 14, 15, 16, 17, 18, 19, 20, 21, 22), 238.3/1 (3/8"), 238.4/1 (3/8" x 250, 3/8" x 125), 238.6/1 (3/8"), 238.1/1ABI (3/8"), 238.2/1BI (3/8"), 238.7/1 (3/8" - 1/2")

MADE FOR WORK.

GARNITURE ORODJA

263

Ključ momentni, nastavljivi



SKENIRAJTE



626765	3/8" / 12 - 60Nm	299,03	178,90
626766	1/2" / 40 - 200Nm	313,26	187,90
626767	1/2" / 60 - 340Nm	496,33	297,90



MADE FOR WORK.

15 kosov

99,21

59,90



7 kosov

90,59

53,90



190H12P15 | 622635

Garnitura nasadnih ključev 1/2" na obešalu

☐ **190/1 12p** (10, 12, 13, 14, 15, 16, 17, 18, 19, 21, 22, 24, 27, 30, 32), **190H** (450)

193TXCS | 607888



Garnitura ključev s TX profilom in T ročajem v kartonu

— **193TX** (TX 10, TX 15, TX 20, TX 25, TX 30, TX 40, TX 45)

SKENIRAJTE





23 kosov

75 zob
4,8° kot zasuka
Varnostni sistem zaklepanja

288,32

172,90

190BI6P23 | 612779



Garnitura nasadnih ključev 1/2" v kovinski kaseti

190/1 6P (10, 11, 12, 13, 14, 15, 16, 17, 18, 19, 20, 21, 22, 23, 24, 27, 30, 32), 190.1/1ABI (1/2"), 190.3/1 (1/2"), 190.4/1 (1/2"x125, 1/2"x250), 190.6/2 (1/2")

24 kosov



325,63

194,90

190BI6P24 | 611939

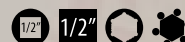

Garnitura nasadnih ključev 1/2" v kovinski kaseti

190/1 6P (10, 11, 12, 13, 14, 15, 16, 17, 18, 19, 20, 21, 22, 23, 24, 27, 30, 32), 190.1/1ABI (1/2"), 190.2/1BI (1/2" x 380), 190.3/1 (1/2"), 190.4/1 (1/2" x 125, 1/2" x 250), 190.6/2 (1/2")



14 kosov

624,19

374,90

197MB2 | 600954



Garnitura nasadnih ključev 3/4" v kovinski kaseti

197/1 6P (22, 24, 27, 30, 32, 36, 38, 41, 46, 50), 197.1/1 (3/4" x 500), 197.3/1 (3/4"), 197.4/1 (3/4" x 400, 3/4" x 200)

199MB1 | 603095

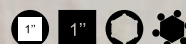

Garnitura nasadnih ključev 1" v kovinski kaseti

12 kosov



1.208,07

724,90

199/1 6P (46, 50, 55, 60, 65, 70, 75, 80), 199.1/1 (1"), 199.3/1 (1"), 199.4/1 (1"x400, 1"x200)

MADE FOR WORK.

KLEŠČE

ŠIROK NABOR RAZLIČNIH ORODIJ IN OPREME ZA DELAVNICE, KOT SO STANDARDNA ORODJA, MOTORISTIČNA ORODJA, AVTOMOBILSKA ORODJA, KOLESARSKA ORODJA, IZOLIRANA ORODJA (VDE CERTIFICIRANO DO 1000 V) IN DRUGO.

EU
MANUFACTURER
SINCE
1919

★
HIGH
QUALITY
GUARANTEE

Premium Hard
Plus ogljikovo jeklo

Specialno ogljično konstrukcijsko jeklo, skladno z EuroDirective 2000/53/EC in s standardom EN 10058.

21,84

12,90

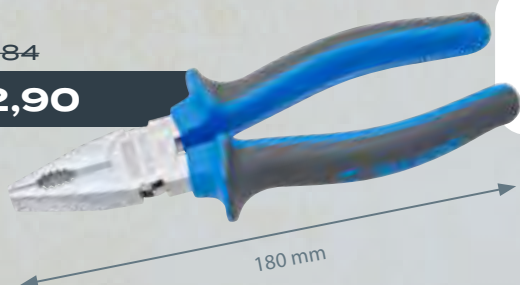

SKENIRAJTE

406/1BI | 607871

Klešče kombinirane

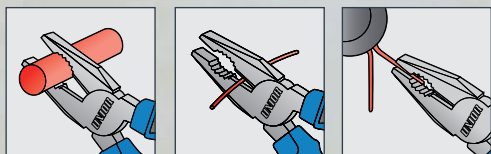

406/4G | 608675

Klešče kombinirane

16,59

9,90

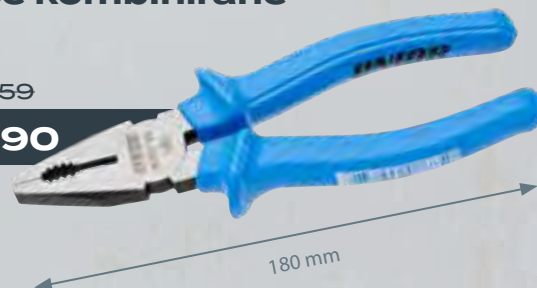

442/1HYPO | 611780

Klešče samonastavljive "HYPO"

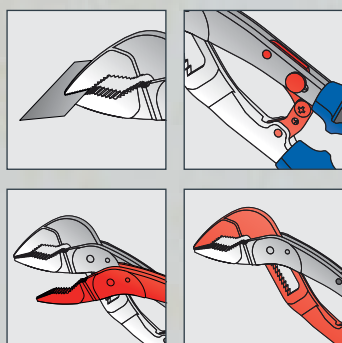

240 mm

45,46

26,90

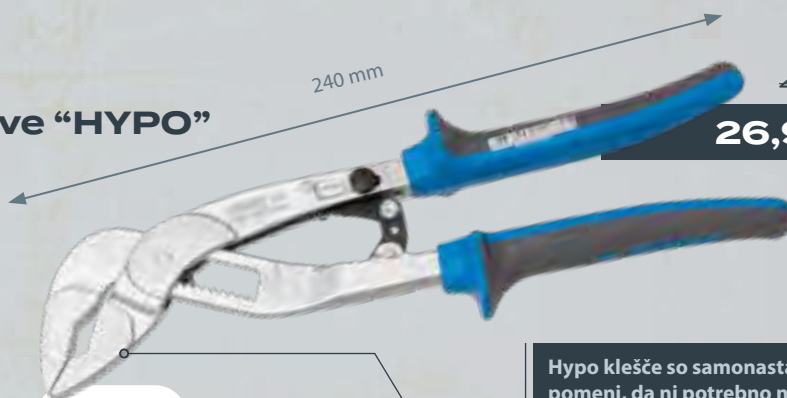

SKENIRAJTE

Hypo klešče so samonastavljive, kar pomeni, da ni potrebno nastavljati širine prijema.

maksimalni oprijem predmeta dela je $\varnothing 40$ mm

MADE FOR WORK.

46,70

27,90

SKENIRAJTE



regulacija odprtine čeljusti v 10 stopnjah

maksimalni oprijem predmeta dela je $\varnothing 40$ mm

447/1HPP | 620172

Klešče univerzalne

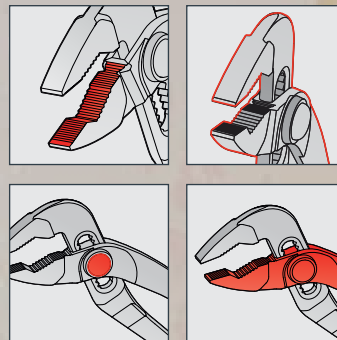

447/4PHPP | 620421

Klešče univerzalne

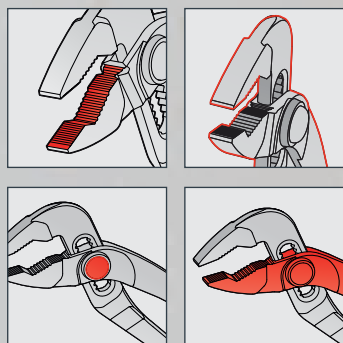

35,61

20,90



SKENIRAJTE

maksimalni oprijem predmeta dela je $\varnothing 40$ mm



407/4DP | 628800

Klešče za vijake

SKENIRAJTE



31,29

18,90

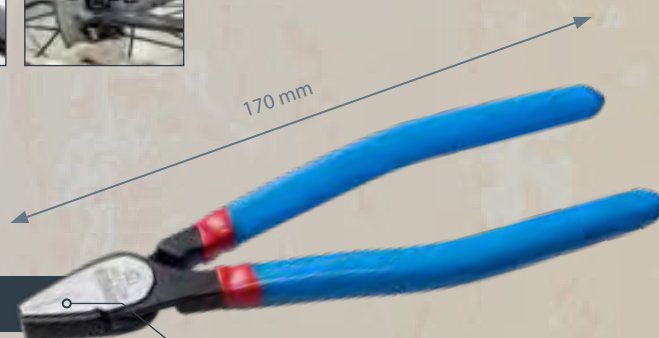

dvojno ozobljenje čeljusti, vzdolžno in prečno

Slike proizvodov so simbolične. Vse dimenzije so v mm, masa v g.

KLEŠČE

22,51

12,90

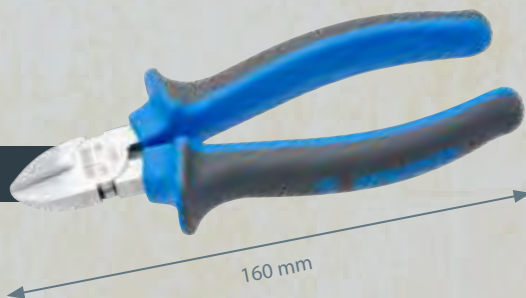

461/1BI | 607884

Klešče stranske, ščipalne

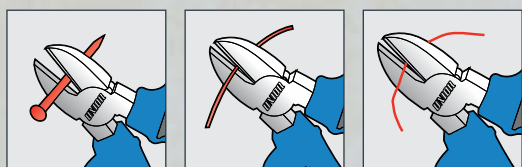

17,81

10,90



461/4G | 608698

Klešče stranske, ščipalne

180 mm

24,27

13,90

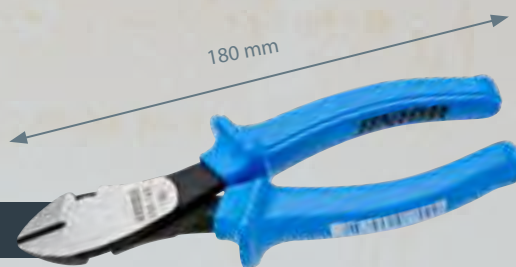

466/4G | 608700

Klešče stranske, ščipalne, močne

31,48

18,90

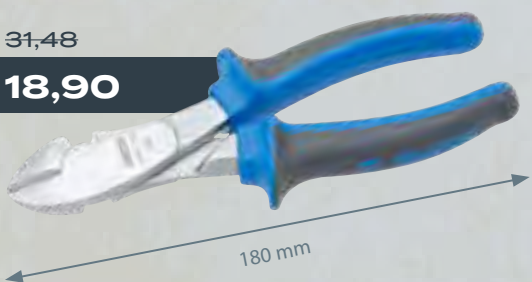

466/1BI | 608850

Klešče stranske, ščipalne, močne

max 2150 N/mm ² Ø $\bar{\Gamma}$	max 650 N/mm ² Ø $\bar{\Gamma}$
1,8	3,0

44,51

26,90



250 mm

za natančno rezanje mehkih (do 6 mm), trdih (do 3,5 mm) in piano žic (do 3 mm).

467SHARK/4DP | 626490

Klešče ščipalne POWERSHARK

469SHARK/4DP | 626500

Klešče ščipalne BOLTSHARK z utorom

Za natančno rezanje mehkih (do 6 mm), trdih (do 4 mm) in klavirskih žic (do 3,6 mm).

50,41

29,90



200 mm

MADE FOR WORK.

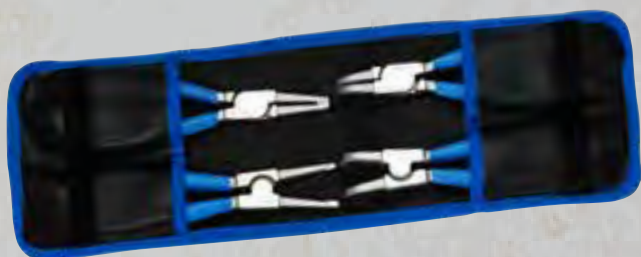

539PLUS/1PCT | 621624

Garnitura seger klešč v torbici

621624	140 (10 - 25mm)	98,67	58,90
621623	140 (3 - 13mm)	98,67	58,90
621625	180	105,27	62,90

514/1BI | 612782

Klešče električarske, multifunkcionalne

26,62

15,90



Stiskanje izoliranih igličastih kontaktov.



Snemanje izolacij od $\varnothing 2,2$ mm do $\varnothing 3,0$ mm.



Snemanje izolacij od $\varnothing 3,5$ mm do $\varnothing 4,0$ mm.



Nazobljena čeljust preprečuje zdrs. Oprijem kablov in žic je boljši.



Stiskanje kabelskih kontaktov do $\varnothing 4,0$ mm.

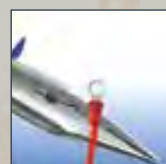

Nazobljena čeljust preprečuje zdrs. Oprijem kablov in žic je boljši.

380 | 610925

Klešče za snemanje izolacije

- avtomatsko snemanje izolacije kablov in prevodnikov 0,2 - 6 mm²

SKENIRAJTE



prilagajanje dolžine rezanja 5 - 12 mm

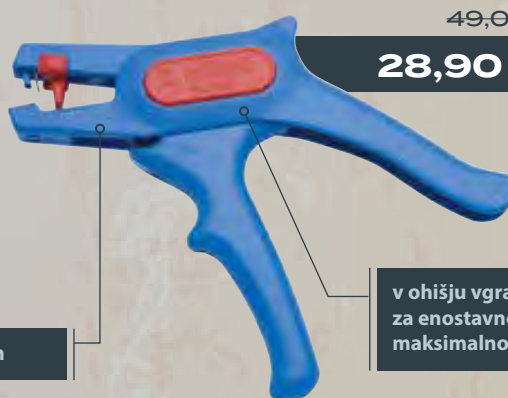

Slike proizvodov so simbolične. Vse dimenzije so v mm, masa v g.

ORODJE ZA OBDELAVO KABLOV

SKENIRAJTE



580/1BI | 609238

Škarje za kable

- za rezanje kablov brez jeklene žice do 10 mm

43,85

25,90



170 mm

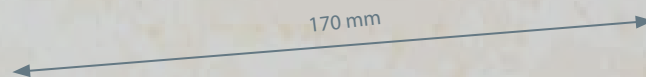

582/3BI | 629398

Škarje za žico

- rezilo z zobmi iz nerjavečega jekla
- nederseči dvobarvni ročaji iz ABS materiala z gumijasto prevleko, ki so izpostavljeni obrabi, kar zagotavlja visoko udobje pri dolgotrajni uporabi
- zatič z nastavljivim vijakom

25,38

14,90



145mm

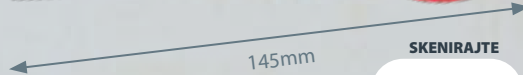

SKENIRAJTE



582/3PR | 629397

Škarje za žico

- rezilo z zobmi iz nerjavečega jekla
- ABS ročaj
- funkcije rezanja kablov na rezilu
- zatič z nastavljivim vijakom

14,88

8,90



140 mm

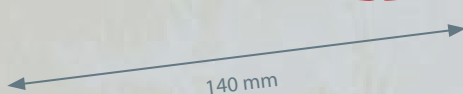

1018A | 628819

Garnitura orodja VDE, premium

42 kosov



1113 (460x270x400), 110/2VDEDP (10, 13, 14, 17, 19, 22), 180/2VDEDP (10, 13, 14, 17, 19, 22), 190.1AVDEDP (1/2"), 190.4/2VDEDP (1/2"x125), 190.4/2VDEDP (1/2"x250), 190.5/2VDEDP (250), 190.2LVDEDP (10, 11, 12, 13, 14, 17, 19, 22, 24), 385AVDEDP (180), 385H (4 - 28), 406/1VDEBI (180), 447/1VDEBI (240), 466/1VDEBI (180), 467SHARK/4DP (250), 478/1VDEBI (160), 514/1BI (160), 580/1VDEBI (230), 603VDETB (0.4 x 2.5x75, 0.8 x 4.0x100, 1.0 x 5.5x125, 1.2 x 6.5x150), 613VDETB (PH1x80, PH2x100), 630VDE (0.6 x 3.5x180)

1.262,58

756,90

SKENIRAJTE



MADE FOR WORK.

Izolirana VDE orodja Unior zagotavljajo varno delo.

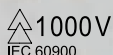

Uporaba do 1000 V napetosti.



Oznaka inštitucije, ki certificira orodja (VERBAND DEUTSCHER ELEKTROTECHNIKER).



Oznaka, da je orodje v skladu s predpisanim standardom (DIN), ki predpisuje osnovne zahteve za orodje (dimenzija, trdota, mehanski preizkusi ...).

461/1VDEBI | 610427

Klešče stranske, ščipalne

28,84

16,90

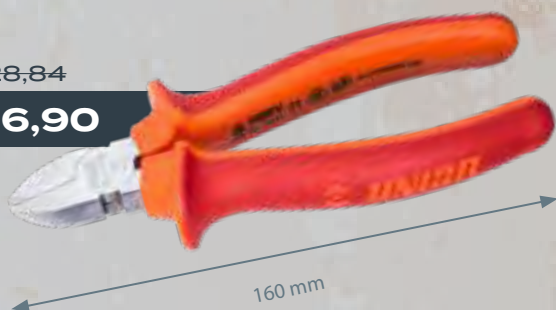

6 kosov



34,55

20,90

603CS6TVDE | 617045



Garnitura izvijačev VDE s preizkuševalcem napetosti v kartonu

- 603VDE (0.8 x 4.0x100, 1.0 x 5.5x125, 1.2 x 6.5x150),
- 613VDE (PH1x80, PH2x100),
- 630VDE (0.5 x 3.0x140)

406/1VDEBI | 610422

Klešče kombinirane

27,63

16,90



6 kosov



32,34

18,90

603CS6AVDE | 617655

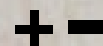

Garnitura izvijačev VDE v kartonu

- 603VDE (0.4 x 2.5x75, 0.5 x 3.0x100, 0.8 x 4.0x100, 1.0 x 5.5x125),
- 613VDE (PH1x80, PH2x100)

45,68

26,90

6 kosov



603CS6TVDEBTBI | 617043

Garnitura izvijačev VDE TBI

- 603VDEBTBI (0.8 x 4.0x100, 1.0 x 5.5x125, 1.2 x 6.5x150),
- 613VDEBTBI (PH1x80, PH2x100),
- 630VDE (0.5 x 3.0x140)

MADE FOR WORK.

IZOLIRANO ORODJE

53 kosov



1.087,75

649,90

SKENIRAJTE



971/2VDE | 608541

Garnitura orodja v kovčku

62 kosov



998,96

598,90

971/3VDE | 612548

Garnitura orodja v kovčku

1000T, 969S (500x420x200)

42,22

24,90

5 kosov



600CS5TBI | 614007

Garnitura izvijačev TBI s šestkotnim nastavkom v kartonu

— 605TBI (0.8 x 4.0x100), — 600TBI (1.0 x 5.5x100, 1.2 x 6.5x125), — 616TBI (PH 1x80, PH 2x100)

52,98

31,90

7 kosov



621CS7TBI | 612300

Garnitura izvijačev TBI s TX profilom v kartonu

— 621TBI (TX 10, TX 15, TX 20, TX 25, TX 27, TX 30, TX 40)

5 kosov

25,39

14,90



606CS5CR | 617017

Garnitura izvijačev CR v kartonu

— 605CR (0.5 x 3.0x80, 0.8 x 4.0x100, 1.0 x 5.5x125, 1.2 x 6.5x150, 1.2 x 8.0x175)

5 kosov

17,86

10,90



607B5NI | 617037

Garnitura izvijačev NI v kartonu

— 605NI (0.5 x 3.0x80, 0.8 x 4.0x100, 1.2 x 6.5x150), — 615NI (PH 1x80, PH 2x100)

MADE FOR WORK.

Premium kaljeno 31CrV3 orodno jeklo za dolgotrajno obstojnost

Ergonomski ročaj CR in NI

Trikomponentni ročaj TBI

Odličen oprijem

607CS7E | 620960

Garnitura izvijačev za elektroniko v kartonu

7 kosov

38,54

22,90



— **605E** (0.3 x 1.8x60, 0.4 x 2.5x75, 0.5 x 3.0x100, 0.8 x 4.0x100), — **615E** (PH 00x60, PH 0x60, PH 1x80)

SKENIRAJTE



3 kosov

75,60

44,90



402A | 617818

Garnitura klešč v kartonu

— **406/1BI** (180), — **461/1BI** (160), — **445/1BI** (240)

SKENIRAJTE



402B | 617933

Garnitura klešč v kartonu

— **406/4G** (180), — **461/4G** (160), — **445/4G** (240)

59,65

35,90



SKENIRAJTE



Slike proizvodov so simbolične. Vse dimenzije so v mm, masa v g.

482/6

Klešče cevne - kotne 45°, S - čeljust

SKENIRAJTE



	⌀	⌀ ^{max}	L		
601511	1"	50	335	41,49	24,90
601512	1.1/2"	60	430	54,74	32,90
601510	1/2"	35	265	34,67	19,90
601513	2"	80	545	90,52	53,90
601514	3"	105	700	161,92	96,90



400 | 612599

Garnitura cevnih in univerzalnih pretaknjenih klešč v kartonu

482/6 (1", 1.1/2"), 447/6 (240)

134,31

79,90

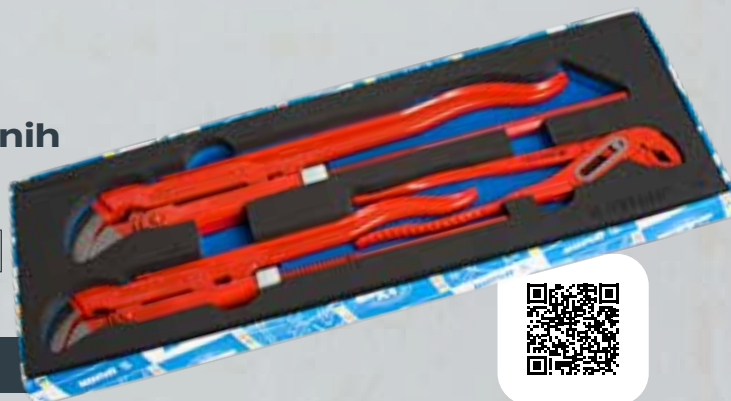

SKENIRAJTE

360/6A | 626187

Rezalec cevi

- hitra menjava rezil
- 4 valčki za boljše vprijetanje in rezanje cevi
- možna individualna uporaba NOGA obrezovalca ostrih robov

626187	3-35mm	54,35	32,90
--------	--------	--------------	--------------



SKENIRAJTE



material: Premium
Hard Plus ogljikovo
jeklo

Specialno ogljično konstrukcijsko jeklo, skladno z
EuroDirective 2000/53/EC in s standardom EN
10058.

596/6A

Škarje za rezanje betonskega železa

blažilci na zglobeh blažijo udarce
ročajev, ki se pojavljajo pri rezanju
betonskega železa



SKENIRAJTE

	L	max 1600 N/mm ² Øř	max 650 N/mm ² Øř		
610965	450mm	5	8	87,86	52,90
610966	600mm	7	10	114,89	68,90
610967	750mm	8	13	150,60	89,90
610968	900mm	9	16	204,22	121,90



SKENIRAJTE



531/4

Klešče za betonske armature

	L		
601373	224mm	16,88	9,90
601374	250mm	18,84	10,90
601375	280mm	21,63	12,90

Slike proizvodov so simbolične. Vse dimenzije so v mm, masa v g.

MADE FOR WORK.

Pnevmatska orodja ponujajo učinkovito, varno in preprosto rešitev.



Registrirajte svoj izdelek!

NOVA LINIJA

Nova linija pnevmatskih orodij je izdelana iz kompozitnega materiala, ki omogoča enostavnejšo in dolgotrajnejšo uporabo.

- ergoničen ročaj za enostavno uporabo
- omogoča hitro in preprosto ter varno in učinkovito izvedbo dela.
- varno delovanje v skladu z najvišjimi varnostnimi standardi.
- nizek hrup med delovanjem

MADE FOR WORK.

1/2"



305,34

182,90

SKENIRAJTE



maks. vrtilni moment 814 Nm

1561 | 615322

Vijačnik udarni

- prosti tek 8000 obratov na minuto
- maks. delovni tlak : 6,2 bar
- poraba zraka 113 l/min
- dovod zraka 1/4"
- maks. velikost vijaka M16

1562 | 615321

Vijačnik udarni

- prosti tek 7000 obratov na minuto
- maks. delovni tlak : 6,2 bar
- poraba zraka 119 l/min
- dovod zraka 1/4"
- maks. velikost vijaka M18

1/2"



384,34

229,90

maks. moment 949 Nm

323,35

193,90

1/2"

maks. vrtilni moment 1223 Nm

kompozitno ohišje



Regulator zraka
(3 različne hitrosti za naprej/nazaj)

Ena roka - naprej/nazaj

NOVA LINIJA

1566 | 627570

Vijačnik udarni

- prosti tek 8000 obratov na minuto
- maks. delovni tlak : 6,2 bar
- poraba zraka 113 l/min
- dovod zraka 1/4"
- maks. velikost vijaka M24



3/4"

maks. vrtilni moment 2034 Nm

680,66

407,90

SKENIRAJTE



NOVA LINIJA

1573 | 627571

Vijačnik udarni

- prosti tek 5500 obratov na minuto
- maks. delovni tlak : 6,2 bar
- poraba zraka 198 l/min
- dovod zraka 3/8"
- max velikost vijaka M30

Slike proizvodov so simbolične. Vse dimenzije so v mm, masa v g.

MADE FOR WORK.



272,28

162,90

1/2"

maks. vrtilni moment 745 Nm

NOVA LINIJA

1563 | 627568

Vijačnik udarni, mini

- prosti tek 8000 obratov na minuto
- priporočen delovni tlak : 6,2 bar
- poraba zraka 164 l/min
- maks. velikost vijaka M20
- Obvezna uporaba Unior IMPACT ključev.



1.415,38

848,90

1"

maks. vrtilni moment 2439 Nm

1592 | 615326

Vijačnik udarni

- prosti tek 4000 obratov na minuto
- maks. delovni tlak : 6,2 bar
- poraba zraka 340 l/min

710P

Meter



Debelina rezila 0,14 mm

klasa natančnosti II

		standout			
612133	2m	1,6m	11,16	6,90	
612134	5m	2m	19,80	11,90	
612135	10m	2,6m	25,10	14,90	





5,69
3,50

556A | 616853

Nož univerzalni

3 avtomatsko izmenljivih segmentiranih rezil v ročaju za 627548 in 616853

SKENIRAJTE



2087 | 619929

Pobiralec upogljiv z magnetom

- Dolžina: 500 mm



24,62
14,50



SKENIRAJTE



67,50
39,90

6 LED lučk gori približno 3 ure,
1 LED na vrhu 7 ur

2091 | 620237

Svetilka LED



MADE FOR WORK.

Distibuter za Slovenijo:



Metal Mikulić d.o.o.

Rusjanova ulica 1, 1235 Radomlje

T: 01 72 95 111

E: info@metalmikulic.si

www.metalmikulic.si

Spremljajte nas:

